

Assignment 9 – page 1 - Solutions

- 53 Water flows through a long, horizontal, conical diffuser at the rate of  $4.2 \text{ m}^3/\text{s}$ . The diameter of the diffuser changes from  $1.0 \text{ m}$  to  $1.6 \text{ m}$ . The pressure at the smaller end is  $9.5 \text{ kPa}$ . Find the pressure at the downstream end of the diffuser, assuming frictionless flow. Assume also, that the angle of the cone is small enough that the flow does not separate from the walls of the diffuser.

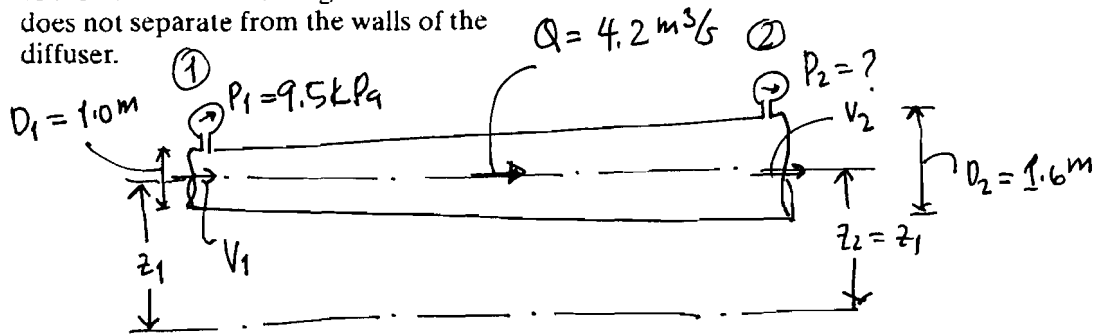

Continuity  $Q = A_1 V_1 = \frac{\pi D_1^2}{4} V_1 \Rightarrow V_1 = \frac{4Q}{\pi D_1^2} = \frac{4 \times 4.2 \text{ m}^3/\text{s}}{\pi \times (1.0 \text{ m})^2} = 5.35 \text{ m/s}$   
 $Q = A_2 V_2 = \frac{\pi D_2^2}{4} V_2 \Rightarrow V_2 = \frac{4Q}{\pi D_2^2} = \frac{4 \times 4.2 \text{ m}^3/\text{s}}{\pi \times (1.6 \text{ m})^2} = 2.09 \text{ m/s}$

BERNOULLI (frictionless)  $z_1 + \frac{P_1}{\rho} + \frac{V_1^2}{2g} = z_2 + \frac{P_2}{\rho} + \frac{V_2^2}{2g} \Rightarrow \frac{P_2}{\rho} = \frac{P_1}{\rho} + \frac{V_1^2 - V_2^2}{2g}$   
 (Note:  $z_1 = z_2$  is indicated as "same")

~~$P_2 = P_1 + \frac{1}{2} \rho (V_1^2 - V_2^2)$~~   $\Rightarrow P_2 = P_1 + \frac{1}{2} \rho (V_1^2 - V_2^2) = 9.5 \times 10^3 \text{ Pa} + \frac{1}{2} \times 1000 \frac{\text{kg}}{\text{m}^3} \times \left( \frac{5.32^2 - 2.09^2}{2} \right) \frac{\text{m}^2/\text{s}^2}{\text{m/s}^2}$

$P_2 = 21467.15 \frac{\text{kg} \cdot \text{m}/\text{s}^2}{\text{m}^2} = 21.46 \text{ kPa}$

Assignment 9 – page 2 - Solutions

5.12 Refer to Fig. P5.4. Water at  $10^\circ\text{C}$  flows up pipe AB (5 m long, 40 mm diameter) and along BC (3 m long, 30 mm diameter) at 1.75 L/s. If the measured pressure at A is 250 kPa, and the pipe friction head loss between A and C is 1.45 m, find the pressure at C. Neglect energy losses caused by the diameter change and bend at B.

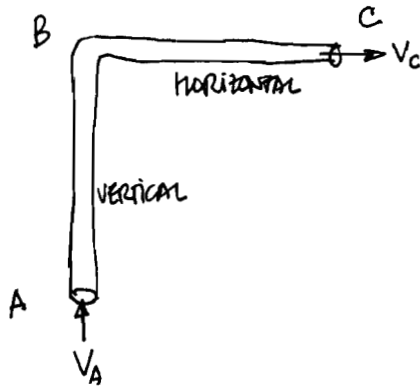

For water at  $T=10^\circ\text{C}$ ,  $\gamma = 9.804 \text{ kN/m}^3$   
 also,  $c = 4187 \text{ N}\cdot\text{m}/(\text{kg}\cdot\text{K})$  or  $\text{m}^2/\text{s}^2\cdot\text{K}$

$$L_{AB} = 5 \text{ m}, D_{AB} = 40 \text{ mm} = 0.04 \text{ m}$$

$$L_{BC} = 3 \text{ m}, D_{BC} = 30 \text{ mm} = 0.03 \text{ m}$$

$$P_A = 250 \text{ kPa}, (h_f)_{AC} = 1.45 \text{ m}$$

$$P_C = ?$$

ENERGY EQUATION BETWEEN POINTS (A) and (C)

$$\left( \frac{P_A}{\gamma} + z_A + \frac{V_A^2}{2g} \right) - (h_f)_{AC} = \left( \frac{P_C}{\gamma} + z_C + \frac{V_C^2}{2g} \right)$$

$$\text{TAKE } z_A = 0, z_C = L_{AB} = 5 \text{ m}$$

$$Q = 1.75 \text{ L/s} = 1.75 \times 10^{-3} \text{ m}^3/\text{s} \quad \left[ \frac{250 \times 10^3}{9.804 \times 10^3} + 0 + \frac{1.39^2}{2 \times 32.2} - 1.45 = \frac{P_C}{\gamma} + 5 + \frac{2.48^2}{2 \times 32.2} \right]$$

$$V_A = \frac{4Q}{\pi D_{AB}^2} = \frac{4 \times 1.75 \times 10^{-3} \text{ m}^3/\text{s}}{\pi \times (0.04 \text{ m})^2} = 1.39 \text{ m/s}$$

$$V_C = \frac{4Q}{\pi D_{BC}^2} = \frac{4 \times 1.75 \times 10^{-3} \text{ m}^3/\text{s}}{\pi \times (0.03 \text{ m})^2} = 2.48 \text{ m/s}$$

$$25.53 = \frac{P_C}{\gamma} + 5.10 \Rightarrow \frac{P_C}{\gamma} = 20.15 \text{ m}$$

$$P_C = 20.15 \text{ m} \times 9.804 \text{ kN/m}^3$$

$$\underline{P_C = 197.55 \text{ kPa}}$$

Assignment 9 – page 3 - Solutions

5.14 Water at 15°C flows up a 24-m-long conical pipe with its centerline sloping at 3° to the horizontal. At its lower end the diameter is 600 mm, the water pressure is 94.6 kPa, and the velocity is 1.3 m/s; at its upper, outlet end the diameter is 450 mm and the water pressure is 78.4 kPa. Find the shear stress at the wall, assuming it to be nonvarying. (Hint: You may use the mean diameter to find the pipe friction head loss.)

Water at  $T=15^\circ\text{C}$ ,  $\rho = 9.798 \text{ kN/m}^3$

continuity,  $Q = v_1 A_1 = v_1 \frac{\pi D_1^2}{4} = 1.3 \times \frac{\pi \times 0.6^2}{4} \text{ m}^3/\text{s}$

$Q = 0.3675 \text{ m}^3/\text{s}$

$v_2 = \frac{4Q}{\pi D_2^2} = \frac{4 \times 0.3675 \text{ m}^3/\text{s}}{\pi \times (0.45 \text{ m})^2}$

$v_2 = 2.31 \text{ m/s}$

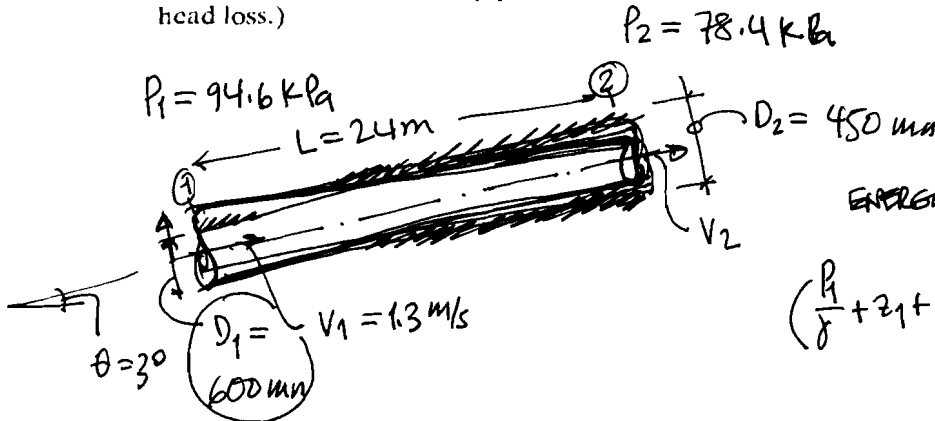

ENERGY EQUATION

$$\left( \frac{P_1}{\rho} + z_1 + \frac{v_1^2}{2g} \right) - h_f = \left( \frac{P_2}{\rho} + z_2 + \frac{v_2^2}{2g} \right)$$

$$h_f = \left( \frac{P_1}{\rho} + z_1 + \frac{v_1^2}{2g} \right) - \left( \frac{P_2}{\rho} + z_2 + \frac{v_2^2}{2g} \right)$$

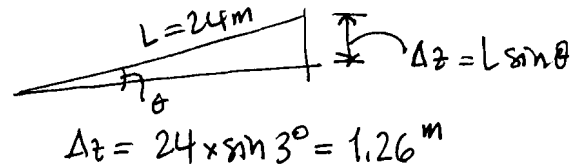

$$h_f = \frac{94.6}{9.798} + z_1 + \frac{1.3^2}{2 \times 32.2} - \left( \frac{78.4}{9.798} + z_1 + 1.26 + \frac{2.31^2}{2 \times 32.2} \right)$$

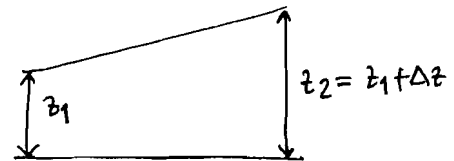

$$h_f = 9.66 + z_1 + 0.026 - (8.00 + z_1 + 1.26 + 0.083)$$

$$h_f = 9.686 - (9.343) = 0.343 \text{ m}, \quad D = \frac{1}{2}(D_1 + D_2) = \frac{1}{2}(0.6 + 0.45) = 0.525 \text{ m}$$

$$h_f = \frac{4\tau_0 L}{\rho D} \Rightarrow \tau_0 = \frac{\rho D h_f}{4L} = \frac{9.798 \times 10^3 \text{ N/m}^3 \times 0.525 \text{ m} \times 0.343 \text{ m}}{4 \times 24 \text{ m}}$$

$$\tau_0 = 18.38 \text{ N/m}^2 = 18.38 \text{ Pa}$$

Assignment 9 – page 4 - Solutions

5.20 Water is flowing at  $12 \text{ m}^3/\text{s}$  through a long pipe. The temperature of the water rises  $0.18^\circ\text{C}$  when heat is transferred to the water at the rate of  $4500 \text{ kJ/s}$ . Find the head loss in the pipe.

$$Q = 12 \text{ m}^3/\text{s} \quad \Delta T = 0.18^\circ\text{C} \equiv 0.18 \text{ K}$$

$$\frac{4500 \text{ kJ}}{\text{s}} = \frac{\text{HEAT TRANSFERRED}}{\text{UNIT TIME}} = \frac{\Delta \text{Heat}}{\Delta t} = \text{Heat}$$

$$Q_H \text{ in eq. (5.25)} = \frac{\text{ENERGY (HEAT)}}{\text{UNIT WEIGHT}} = \frac{\Delta \text{Heat}}{W} = \frac{\Delta \text{Heat}}{\Delta t} \cdot \frac{\Delta t}{W} = \frac{\Delta \text{Heat}}{\Delta t} \cdot \frac{\Delta t}{\rho g \Delta t}$$

$$= \frac{\Delta \text{Heat}}{\Delta t} \cdot \frac{1}{\rho g} \cdot \frac{\Delta t}{\Delta t} = \frac{1}{\rho g} \frac{\Delta \text{Heat}}{\Delta t} \cdot \frac{1}{Q} = \frac{1}{\rho g Q} \frac{\Delta \text{Heat}}{\Delta t} = \frac{\Delta \text{Heat}}{\rho g Q}$$

with  $Q = \frac{\Delta V}{\Delta t}$ , thus  $Q_H = \frac{\text{Heat}}{\rho g Q} = \frac{4500 \times 10^3 (\text{kg} \cdot \text{m}/\text{s}^2) \cdot \text{m}/\text{s}}{1000 \text{ kg}/\text{m}^3 \times 9.81 \text{ m}/\text{s}^2 \times 12 \text{ m}^3/\text{s}}$

$\rho = 1000 \text{ kg}/\text{m}^3$   
 ~~$g = 9.81 \text{ m}/\text{s}^2$~~   
 $g = 9.81 \text{ m}/\text{s}^2$

$$Q_H = 38.23 \text{ m} = 38.23 \text{ J}/\text{N}$$

From eq. (5.25)  $\frac{c}{g} \Delta T = Q_H + h_L \Rightarrow h_L = \frac{c \Delta T}{g} - Q_H$

$$c = 4187 \frac{\text{m}^2}{\text{s}^2 \cdot \text{K}}$$

$$h_L = \frac{(4187 \frac{\text{m}^2}{\text{s}^2 \cdot \text{K}}) (0.18 \text{ K})}{9.81 \text{ m}/\text{s}^2} - 38.23 \text{ m}$$

$$h_L = 76.83 - 38.23 = 38.60 \text{ m}$$

Assignment 9 – page 5 - Solutions

5.22 A pump lifting water at 3.5 cfs adds 35 ft·lb/lb to the flow. The suction line diameter is 8 in., and at intake (elevation 350 ft) the water pressure is 5.2 psi. The discharge line diameter is 6 in., and at outlet (elevation 370 ft) the water pressure is 3.5 psi. Due to cold weather, 7 ft·lb/lb of thermal energy (heat) are lost to the environment. Find the change (rise or fall?) in water temperature between intake and outlet. Assume the specific weight of the water remains constant at 62.4 lb/ft<sup>3</sup>.

$$Q = 3.5 \text{ cfs}, h_p = 35 \frac{\text{ft} \cdot \text{lb}}{\text{lb}}$$

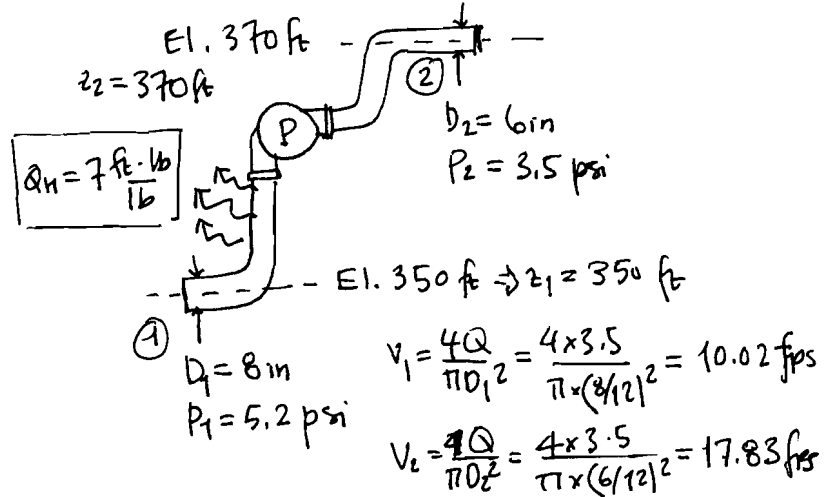

$$\Delta T = T_2 - T_1 = ? \quad \gamma = 62.4 \text{ lb/ft}^3$$

Eq. (5.27)

$$\left( \frac{P_1}{\gamma} + z_1 + \frac{v_1^2}{2g} \right) + h_m - h_L = \left( \frac{P_2}{\gamma} + z_2 + \frac{v_2^2}{2g} \right), \text{ use } h_m = h_p = 35 \text{ ft}$$

$$\frac{5.2 \times 144}{62.4} + 350 + \frac{10.02^2}{2 \times 32.2} + 35 - h_L = \frac{3.5 \times 144}{62.4} + 370 + \frac{17.83^2}{2 \times 32.2}$$

$$\Rightarrow h_L = 15.55 \text{ ft}, \quad \text{NOTE: } c = 25000 \frac{\text{ft} \cdot \text{lb}}{\text{slug} \cdot ^\circ\text{R}}$$

$$\text{Eq. (5.25) or (5.26)} \Rightarrow h_L = \frac{c}{g} \Delta T - Q_H \Rightarrow \Delta T = \frac{g}{c} (h_L + Q_H)$$

NOTE: because the flow is losing thermal energy,  $Q_H = -7 \text{ ft}$

$$\Delta T = \frac{32.2 \frac{\text{ft/s}^2}}{25000 \frac{\text{ft} \cdot \text{lb}}{\text{slug} \cdot ^\circ\text{R}}} \times (15.57 \text{ ft} - 7 \text{ ft}) = 0.011 ^\circ\text{R}$$